

THE COOLANT HEATER OF CHOICE

introducing

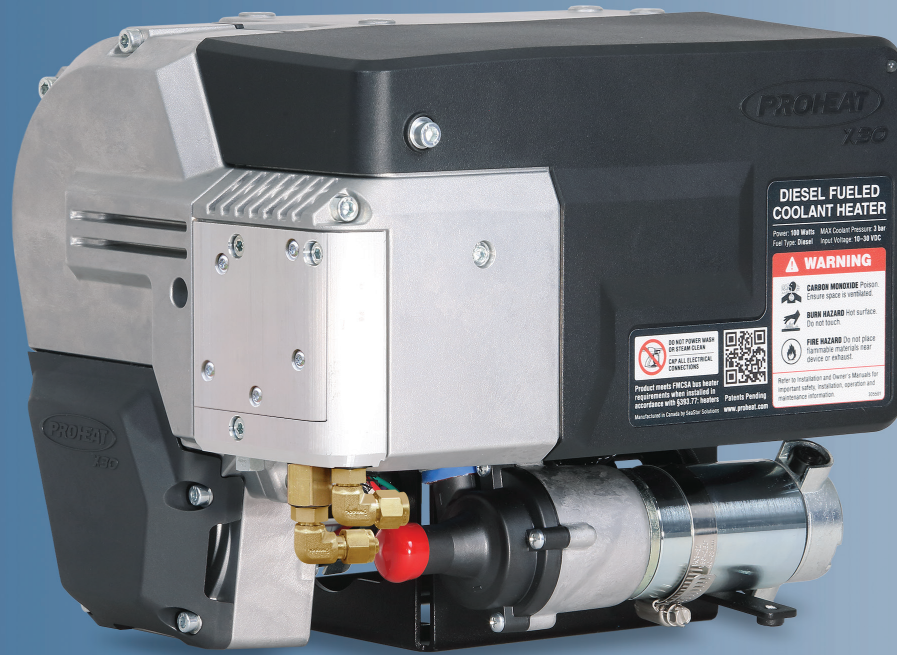

X30 IS SMARTER

X30 is the next generation of smart heater from Proheat. X30 is a diesel powered heating solution for reliable cold weather starting, fluid heating and passenger comfort. Featuring on board O₂ feedback, X30 automatically adjusts for the best possible combustion to suit the environment. Whether temperature,

altitude or system requirements X30 can adapt to nearly any situation. With more than 20 years of field experience, Proheat X30 is truly the next generation of smart heater.

Possible Heating Options

- 1 X30 Heater
- 2 Timer
- 3 Thermostat
- 4 Heat Exchanger
- 5 Heat Probe
- 6 Hydraulic Tank
- 7 Heated Engine
- 8 Cold Coolant Return
- 9 Fuel Pick-Up
- 10 Battery Supply
- 11 Exhaust

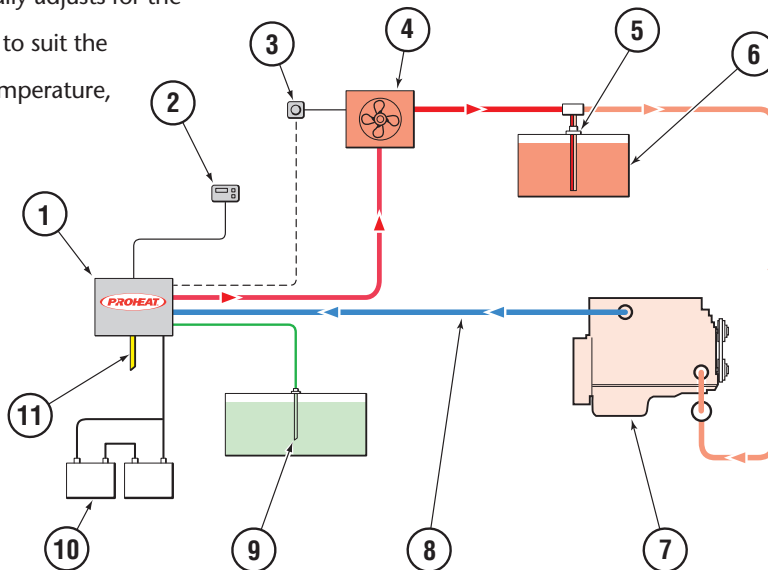

AT A GLANCE

COOLANT HEATER FEATURES

- 10–31kBTU variable heat output
- O₂ feedback for optimum combustion with minimal emissions
- Low pressure fuel system for safe reliable starting under all conditions
- Flexible mounting options to suit many different applications
- Two year parts and labor warranty

NEW FEATURES

- Next generation programmable PCM controller
- J1939 Can bus network
- New operating modes to save battery power and fuel



X30

SPECIFICATIONS

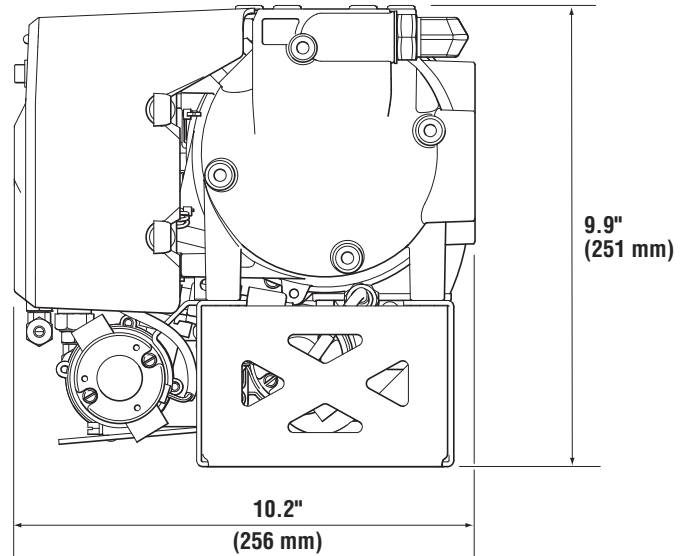
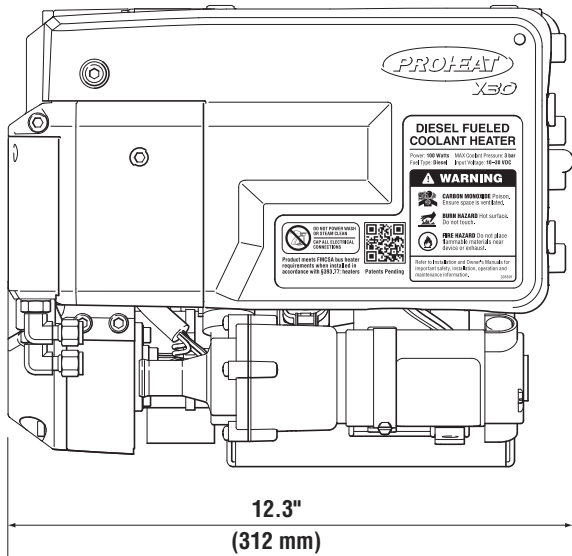

RATING	10,000 – 31,000 BTU (2.9 – 9.1 KW)
OPERATING VOLTAGE RANGE	10 – 30 VDC
POWER CONSUMPTION	90W max.
FUEL CONSUMPTION	0.1 – 0.31 gal/hr. (0.4 – 1.17 L/hr.)
COOLANT FLOW	3.0 gal/min. (11.4 L/min.)
COOLANT TEMPERATURE (at heater)*	150 to 185 °F (65 to 85 °C)
OPERATING TEMPERATURE RANGE	-40 to 185°F -40 to 85°C
FUEL TYPES	Diesel (ULSD #1, #2 and Arctic Blend), Kerosene (K-1), Jet (A, A-1 and JP8), Bio fuels (up to B20)
IGNITION TYPE	Electronic spark ignition
HEAT EXCHANGER CAPACITY	0.36 quart (0.34 litre)
WEIGHT heater only with enclosure	36 lb (16.3 kg) 44 lbs (20 kg)
DIMENSIONS – HEATER (L x W x H)	12.3 x 10.2 x 9.9 inches (312 x 256 x 251 mm)
DIMENSIONS – ENCLOSURE (L x W x H)	13.25 x 11.25 x 11 inches (337 x 286 x 279 mm)
WARRANTY	Two years parts and labor

* Optional set points available.

Installation Kit



PROHEAT X30 KITS

BASIC HEATER	PART NUMBER
BASIC HEATER Electronic controller, coolant pump, mounting base	PH0310

STANDARD HEATER KIT NO ENCLOSURE	PART NUMBER
Includes: Items 1 and 2	PH0320
1. BASIC HEATER ONLY Electronic controller, coolant pump, mounting base	PH0310
2. INSTALLATION KIT ONLY Power wire harness, fuel pick-up and hose, control wire harness, toggle switch, exhaust pipe, nuts, bolts, washers for mounting	PK3003

STANDARD HEATER KIT WITH ENCLOSURE	PART NUMBER
Includes: Items 1, 2 and 3	PH0330
1. BASIC HEATER ONLY Electronic controller, coolant pump, mounting base	PH0310
2. INSTALLATION KIT ONLY Power wire harness, fuel pick-up and hose, control wire harness, toggle switch, exhaust pipe, nuts, bolts, washers for mounting	PK3003
3. ALUMINUM ENCLOSURE ONLY	PK3002



Enclosure

Please Note: Specifications are subject to change without notice.



Proheat is registered trademark of Marine Canada Acquisition Inc. and its subsidiary companies.

