

OWNER'S HANDBOOK

X30

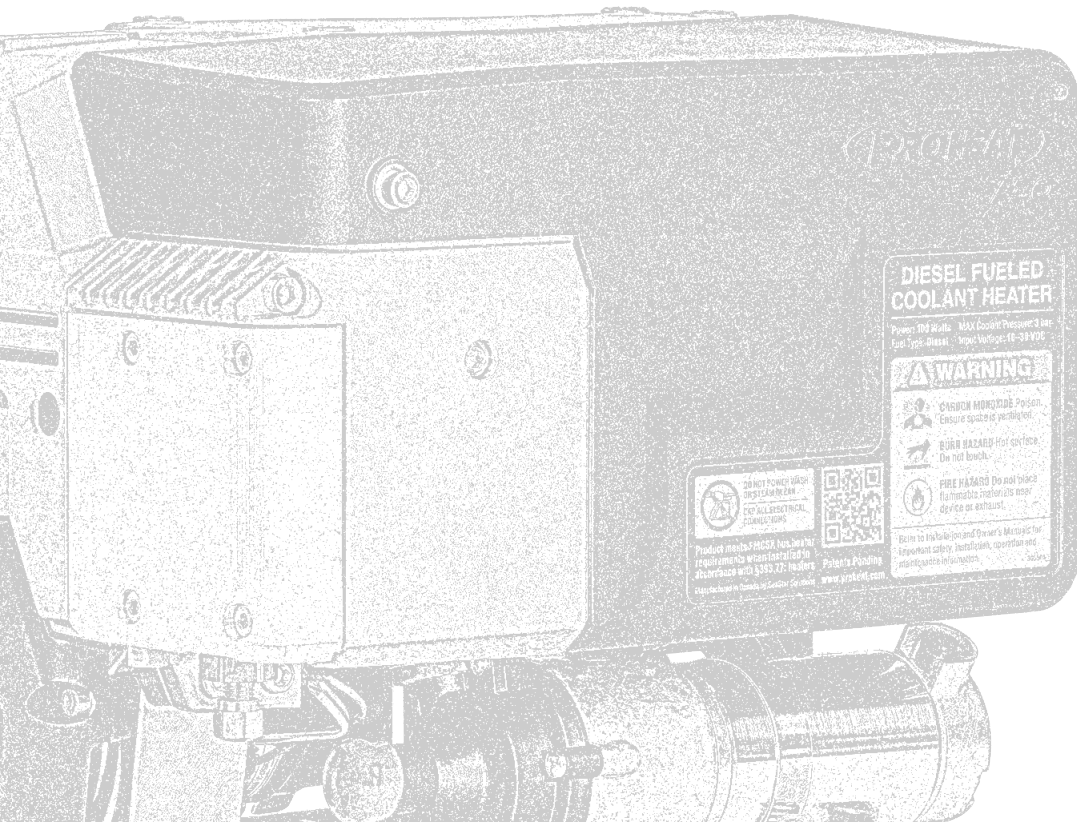

DO NOT POWER WASH OR CLEAN WITH ALL-BRISTLE BRUSHES

Product made by PROHEAT, Inc. See the instructions for when installed in the vehicle with 8453.275 heater is applicable to Canada or Mexico. See model 8453.275 for details.

PROHEAT
www.proheat.com

DIESEL FUELED COOLANT HEATER

Power: 100 W/12V MAX Coolant Pressure: 3 bar
Fuel: 1.5L/HR Diesel Temp. Voltage: 10-30 VDC

WARNING

- CARBON MONOXIDE Poison. Ensure space is ventilated.
- BURN HAZARD Hot surface. Do not touch.
- FIRE HAZARD Do not place flammable materials near device or exhaust.

Refer to the following Owner's Manual for important safety, installation, operation and maintenance information.



Contents

<i>Safety</i>	2
<i>Introduction</i>	4
<i>Operating your PROHEAT</i>	5
<i>Optional Sleeper Fan Operation</i>	7
<i>Toggle Switch – Timer – PFC</i>	8
<i>Timer Instructions</i>	9
<i>PFC Instructions</i>	10
<i>Caring for your PROHEAT</i>	11
<i>Troubleshooting</i>	17
<i>Troubleshooting – Operation Indicators/Diagnostic Codes</i>	18
<i>Troubleshooting – Function Diagnostics</i>	22
<i>Warranty</i>	25
<i>Owner's responsibility</i>	26

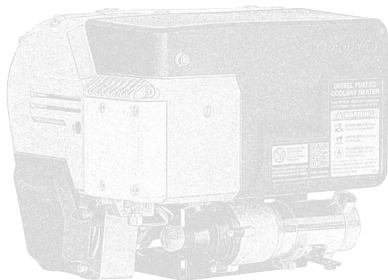

Safety

⚠ WARNING

ELECTRICAL – Electric shock can cause severe personal injury, burns, and death. Before working on any unit, disconnect the batteries. Use only approved materials and methods when working on the electrical system and follow local electrical codes. Never work with electricity in wet conditions or when you are feeling fatigued.

⚠ WARNING

POISONS/TOXINS – Fuel and coolant are toxic and in some cases, carcinogenic. Wear eye and hand protection at all times. Remove contaminated clothing immediately and wash contaminated skin. Do not breathe in vapors.

⚠ WARNING

MOVING/HOT PARTS – Moving/hot parts can cause severe injury and or death. Before working on any unit, shut it off. Do not operate any unit until protective covers have been replaced. Always ensure bolts and clamps are correctly torqued and secured. Inspect mechanical components periodically for damage and corrosion.

⚠ WARNING

COOLANT – *Never* remove the filler cap when the engine is hot – escaping steam or scalding water could cause serious personal injury. The coolant level in the expansion tank should be checked at least weekly (more frequently in high mileage or arduous conditions). Always check the level *when the system is cold*. Unscrew the filler cap slowly, allowing the pressure to escape before removing completely. *Never* run the engine without coolant.

Prevent anti-freeze coming in contact with the skin or eyes. If this occurs, rinse immediately with plenty of water. Anti-freeze will damage painted surfaces.

Never top-up with salt water. Even when travelling in territories where the water supply contains salt, always ensure you carry a supply of fresh (rain or distilled) water.

⚠ DANGER

CALIFORNIA PROPOSITION 65 WARNING – Do not operate heater in garages or in other closed or unventilated areas. Diesel exhaust and some of its constituents are known to the State of California to cause cancer, birth defects, and other reproductive harm.

Electrical components in this product may contain lead, a chemical known to the State of California to cause cancer and birth defects and other reproductive harm.

Safety

Throughout this manual, you will see notes labeled **DANGER**, **WARNING**, **CAUTION** and **NOTICE** to alert you to special instructions or precautions concerning a particular procedure that would be hazardous if performed incorrectly or carelessly.

Observe them carefully!

These safety alerts alone cannot eliminate all hazards. Strict compliance with these special instructions and common sense are major accident prevention measures.

▲ DANGER	▲ WARNING	▲ CAUTION	NOTICE
Immediate hazards that will result in severe injury or death.	Hazards or unsafe practices that could result in severe personal injury or death.	Hazards or unsafe practices that could result in minor injury or product or property damage.	<i>Information that is important to proper installation or maintenance, but is not hazard-related.</i>

Safety Considerations

▲ WARNING

EXHAUST – Inhalation of exhaust gas (containing carbon monoxide) may cause severe personal injury and/or death. Anyone suspected of suffering from CO inhalation should be removed from the hazardous area and given medical assistance immediately.

▲ WARNING

EXPLOSION HAZARD – Do not operate heater where combustible fumes or airborne particles, such as sawdust, are present.

▲ WARNING

FUEL – Exercise extreme caution when working near fuel or fuel-filled equipment. Do not operate heater during fueling operations. In addition, do not smoke or handle open flame equipment, such as a blowtorch, around fuel.

▲ WARNING

FIRE HAZARD – Do not place any flammable items around the heater and exhaust pipe.

▲ WARNING

BATTERIES – Wear hand and eye protection when working near batteries. Do not smoke or use open flames near batteries.

Introduction

Congratulations on your purchase of a PROHEAT X30 diesel-fired heater. This handbook is provided to summarize the operation and maintenance of the PROHEAT X30 for the Owner/Operator.

For complete information, please refer to the Installation and Service manual SL9211 at www.proheat.com

Although trucks have been used throughout this book, applications for PROHEAT are by no means limited to trucks. PROHEAT heaters are designed to be used on any diesel equipped vehicle including: trucks, buses (school, transit and coach), construction equipment, off road equipment, military equipment and cargo.

PROHEAT heaters are used in the following applications:

- Preheats an engine block to ensure reliable cold weather starting.
It is recommended that PROHEAT is used year round (winter and summer) to reduce engine wear associated with cold starting.
- With the engine off—supplies heat to the engine and sleeper for comfort and reduced idle time resulting in cost savings through reduced fuel consumption and engine wear.
- With the engine running—adds heat to the coolant system when the engine does not provide adequate reject heat for the vehicles interior.
- Provides heat to protect cargo from cold weather damage.
- With the engine off - supplies minimal heat to prevent freezing over long periods of time.

NOTICE

ENGINE BLOCK HEAT

ENGINE & SLEEPER HEAT

SUPPLEMENTAL HEAT

CARGO HEAT

ANTI-FREEZE HEAT

Operating your PROHEAT

Your PROHEAT X30 is controlled by either an ON/OFF manual toggle switch or by an optional PROHEAT 7-day timer. The timer can be controlled manually, or it can be set to start at a predetermined time. Both devices have a light that indicates when the heater is operational as well as flashing to indicate an error state. Your installer may have enabled optional features and heating modes. Please see the X30 Installation and Service manual SL9211 at www.proheat.com or your Dealer for more information.

STANDARD MODE OPERATING SEQUENCE

- 1. SWITCH ON** – The ON/OFF switch (or Timer) lamp and the Proheat Control Module (PCM) “ON” LED will light. In addition, the Hour Meter (Auxiliary Output) will be powered. If the coolant temperature is below 150°F (65°C) the PROHEAT enters Pre-check. If the coolant temperature is above 150°F (65°C) the PROHEAT enters Standby.
- 2. PRECHECK** – The PCM performs a short diagnostic cycle. This takes a few seconds to check components for proper ranges, short-circuits and open circuits. If there are no errors indicated, the PROHEAT goes to “Ignition”.
- 3. IGNITION** – The blower starts first, followed by the coolant pump, ignition spark, air compressor and fuel pump. The ignition electrode sparks for up to 60 seconds. Once a good flame is detected, the PROHEAT goes to “Full Output”.
- 4. FULL OUTPUT** – The PROHEAT runs at Full BTU Output until the coolant temperature reaches 185°F (85°C) at the heater outlet. If the time to heat the coolant to 185°F (85°C) is longer than 10 minutes the PROHEAT then shuts the flame off and goes to “Cool Down” (Purge). If the time to heat the coolant to 185°F (85°C) is shorter than 10 minutes the heater will slow down and reduce the heat output for the remainder of the 10 minutes.
- 5. MODULATING BTU OUTPUT** – The PROHEAT may reduce the heat output up to 50% automatically once the coolant temperature reaches 185°F (85°C) at the heater outlet.

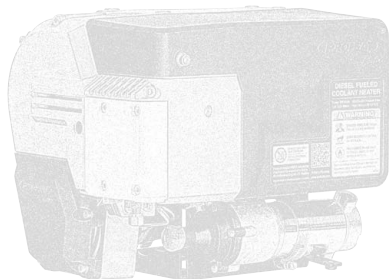



Operating your PROHEAT

The heating cycle will end once the 10 minutes have past OR the coolant temperature reaches 194°F (90°C) at the heaters outlet.

The PROHEAT then shuts the flame off and goes to “Cool down” (Purge).

- 6. COOL DOWN (Purge)** – The air compressor and fuel pump shut off immediately. The blower and coolant pump continue to run. After 3 minutes, the blower stops and the PROHEAT goes to “Standby.”
- 7. STANDBY** – The coolant pump circulates the coolant through the system until the temperature drops to 150°F (65°C) at the heater outlet; then it will enter Precheck and repeat steps 2 to 6. The PROHEAT will continue to repeat steps 2 to 5 until it is switched “off.”
- 8. SWITCH OFF** – If PROHEAT is in Full Output, it will Cool Down (Purge) first, then shut “OFF”. If PROHEAT is in Standby, it will shut “OFF” immediately.
When switched OFF, the Sleeper Fan (if equipped) output turns off.
When switched OFF, the Hour Meter (Auxiliary Output) will shut off.

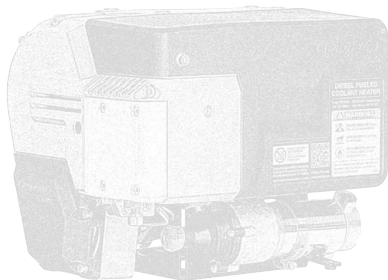

Optional Sleeper Fan Operation

NOTICE

For more information on Sleeper Fan installation, please refer to the Installation and Service manual SL9211 at www.proheat.com

Today's sleepers are designed for maximum comfort for the vehicle operator. Generally the units are larger and have accessories that compete for battery power with auxiliary heaters. PROHEAT is a cost-saving component by reducing fuel consumption and engine maintenance. Therefore, it should be given priority over these accessories.

PROHEAT installation recommendations are designed to allow the operator to:

- Run the PROHEAT with the vehicle ignition key in the OFF position
- Set the desired sleeper ambient temperature using the dedicated Proheat thermostat

The vehicle operator's responsibility is to ensure that:

- Coolant valves used in the heating system are open: These can be manually or electrically operated (electrically operated valves must be opened before shutting the vehicle OFF)
- When operating the PROHEAT, power consuming accessories such as refrigerators, DVD's, TV's, satellite receivers, heated mirrors, etc. are not used to ensure enough starting current for the engine
- Sleeper curtains are closed: The PROHEAT is designed to heat the sleeper and engine as efficiently as possible – heating the cab, fuel tanks and batteries means longer run time which will require more battery power

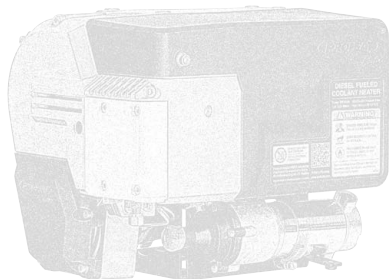



Toggle Switch - Timer - PFC

TOGGLE SWITCH

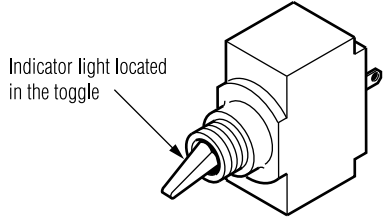

TIMER

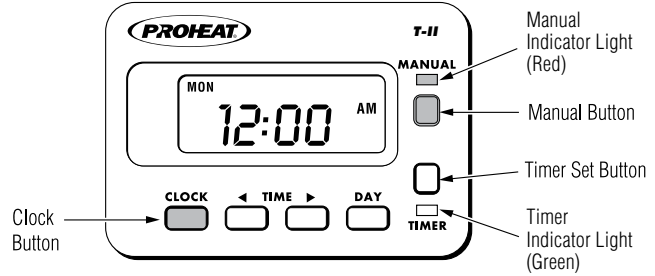

PROHEAT FUNCTION CONTROLLER (PFC)

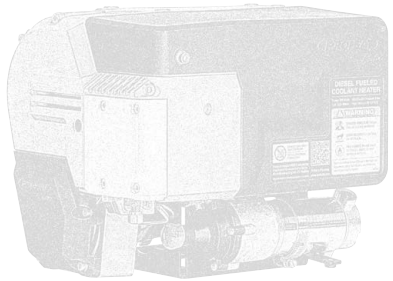

Manual Mode
Solid Red Led = Heater Active
Flashing Red Led = Heater Fault

Timer Mode
Solid Green Led = Timer Active

Back Soft Key
Back (Default) Or No

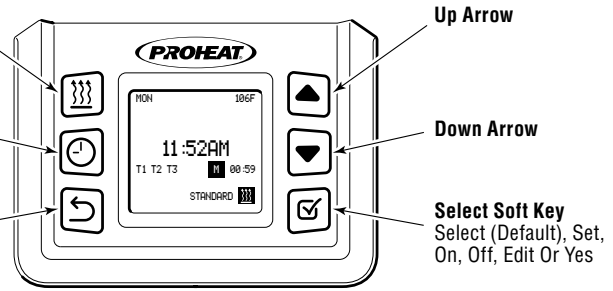

Timer Instructions

NOTICE

For complete Timer information, please refer to the T-II Timer Installation and Operating Instructions 958829 at www.proheat.com

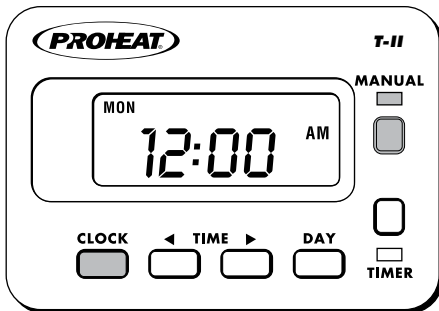
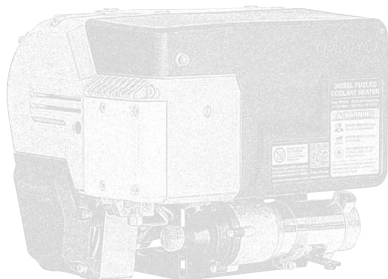

SETTING CLOCK

- STEP 1** Press and hold "CLOCK"
- STEP 2** Press "◀" or "▶" to set time
- STEP 3** Press "DAY" to advance the day.
- STEP 4** Release "CLOCK".

MANUAL OPERATION

MANUAL button is used to turn the PROHEAT On and Off when desired.

- STEP 1** Press "MANUAL" to turn on the PROHEAT (red light will go on and the heater will operate indefinitely).
- STEP 2** Press "MANUAL" again to turn Off the heater (red light and the PROHEAT will turn Off).

TIMED OPERATION

- STEP 1** Press and Hold "TIMER" (green light will turn on and "T1" will flash).
- STEP 2** Press "◀" or "▶" to set time
- STEP 3** Press "DAY" to advance the day.
- STEP 4** Release "TIMER". (green light and "T1" will remain lit to activate timer).



PFC Instructions

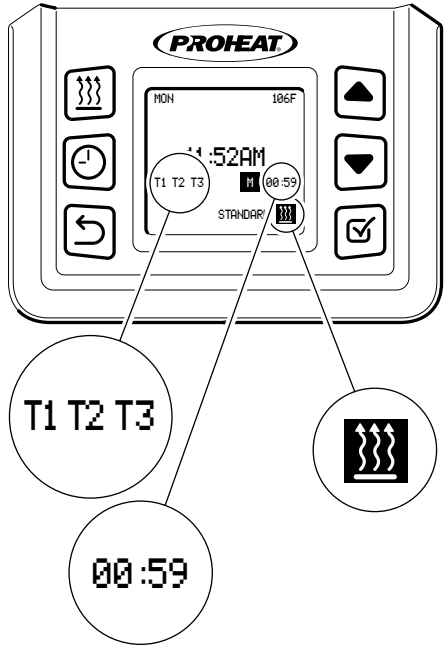

MANUAL OPERATION

The “” button is used to turn the heater on and off when desired regardless of set Timers.

Press “” to activate the heater. The Red Manual Button LED will turn on and the heater will operate indefinitely (factory preset).

If the Manual Mode Runtime has been set you will see the remaining time left before the heater automatically turns off.

When the heater has an active Flame the icon will change to a black background. Pressing “” button again will de-activate the heater. (The Red LED will go out and the heater will turn off.)

TIMED OPERATION

When a Timer Mode is enabled you may see a number of different screens depending on how the Timer was programmed (see Timer settings).

Press the “” button repeatedly to toggle through and activate T1, T2, T3 or Group Timers. (Green Timer LED will turn on).

The Heater will switch on at the set program(s) time, run for the set duration, then switch off automatically.

If the heater has been turned on by a timer event, Pressing “” button will turn the heater off but leaves the timer(s) schedule active.

Pressing the “” Button repeatedly to toggle through and deactivate the current set timer program(s) (Green Timer LED will go out and screen will not show T1,T2,T3).

If a password has been set it may not be possible to deactivate the scheduled timer(s).

NOTICE

For complete PFC information, please refer to the PFC Installation and Operating Instructions 949900 at www.proheat.com

NOTICE

“Manual” and “Timer” cannot be active at the same time. If “” is active and the “” button is pressed, the heater will turn off and the Red Manual Button LED will go out.

Caring for your PROHEAT

Your PROHEAT has been designed to operate with a minimum of maintenance. Always return to your authorized PROHEAT dealer for major service. Your PROHEAT dealer has the specialized equipment necessary to keep your PROHEAT running safely and reliably.

NOTICE

For more maintenance information, refer to the Installation and Service manual SL9211 at www.proheat.com

Operate the PROHEAT year round (winter & summer). Use the PROHEAT to preheat the engine before starting. Savings will result from reduced engine idle time and maintenance. This also keeps the PROHEAT components and fuel system in good running order.

PROHEAT weekly maintenance:

Visually inspect the Proheat, mounting brackets, fuel line, harnesses, coolant lines and exhaust system for damage, loose parts and leakage.

Run the Proheat a minimum of once a week to keep new fuel in the heater's critical components.

PROHEAT annual maintenance:

A higher duty cycle may require a more frequent maintenance schedule.

Proper maintenance will result in the following benefits:

- Maximum heat transfer to the coolant
- Minimum battery power draw
- Long term cost savings
- Increased reliability

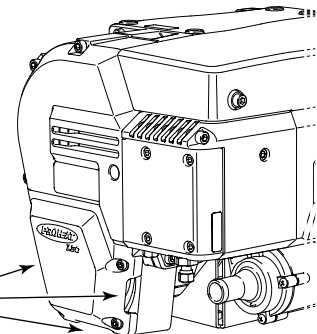
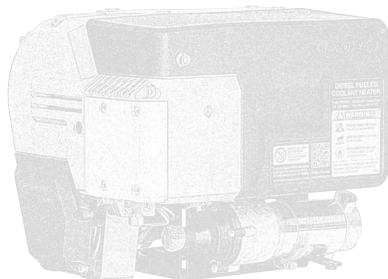

Check Combustion
Air Inlet for restrictions.
Clean as required.

Caring for your PROHEAT

CLEAN HEATER ENCLOSURE

- Remove the heater enclosure cover.
- Clean any accumulated debris or dust from the components.
- Blow out the compartment with compressed air.
- **Do not pressure wash.**

CHECK EXHAUST SYSTEM

- Make sure the exhaust pipe is fully installed, vents outside of the engine compartment and is clear of the underside of the vehicle.
- Check the pipe for dents, restrictions or severely corroded areas and replace if necessary.
- Ensure exhaust pipe clamps are tight.

CHECK FUEL FILTER

- Remove and inspect fuel filter. Clean or replace as necessary.

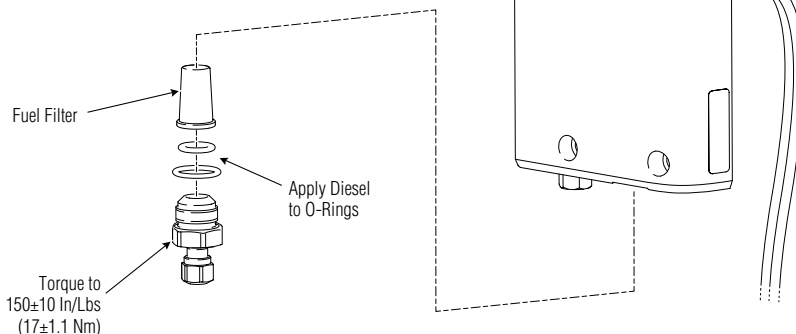
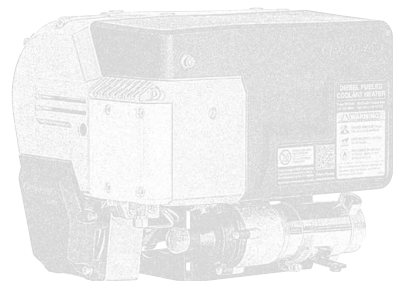

Caring for your PROHEAT

CHECK FUEL SYSTEM

- Check fuel pick-up tube, clamps and line to the heater for damage, cracks from aging or leakage.
- Check fuel pump and fittings for damage or leakage.

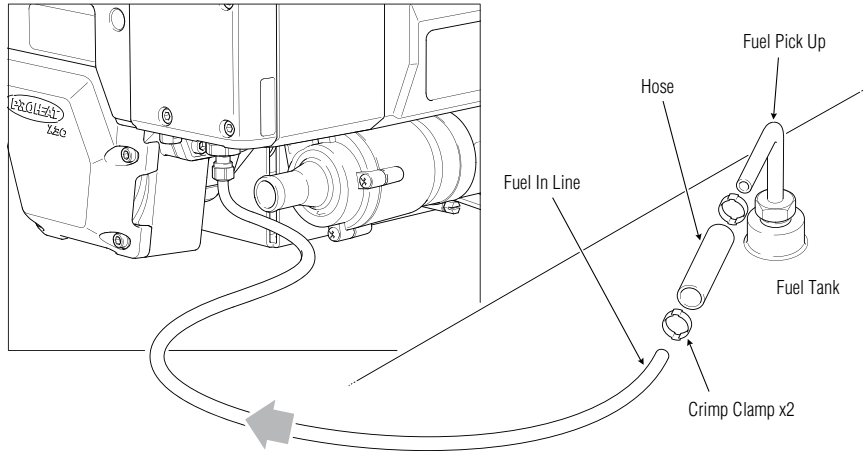
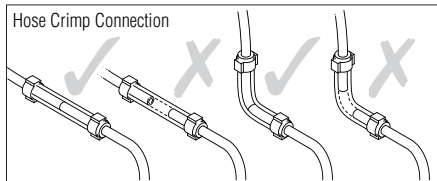

CHECK BATTERIES

- Check the condition of batteries and the power connections. The heater will not function properly with weak batteries or corroded connections.
- **Note** For best results load test each battery individually.

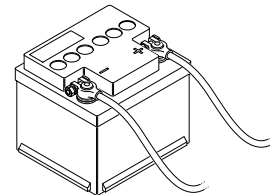

Caring for your PROHEAT

CHECK COOLING SYSTEM

- Check coolant pump, all coolant hoses and connections for signs of leakage or damage.
- Repair or replace as required.

CHECK HEAT EXCHANGER

- To maintain optimum heat output, clean any combustion deposits that may have accumulated on the heat exchanger fins.
- Remove the burner head assembly and combustion tube to access the inside of the heat exchanger.
- Ensure exhaust pipe is clean and free from restriction.
- Use a wire brush to loosen the deposits and a vacuum to remove debris.
- Torque securing screws to 12 ± 3 in/lbs (1.4 ± 0.3 Nm).

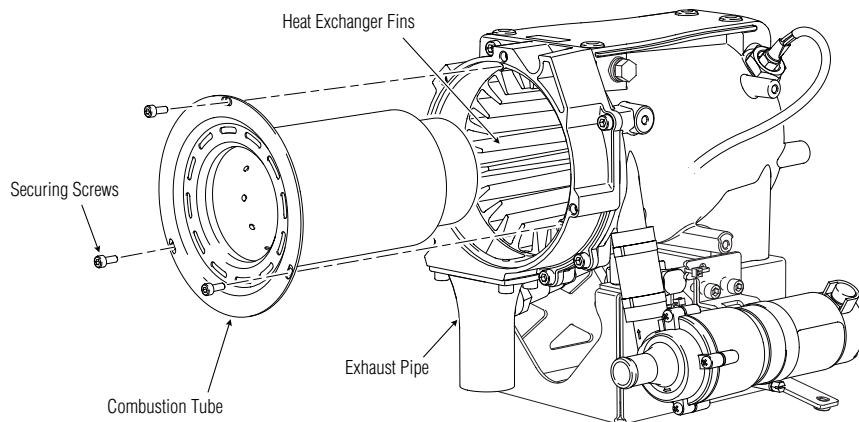
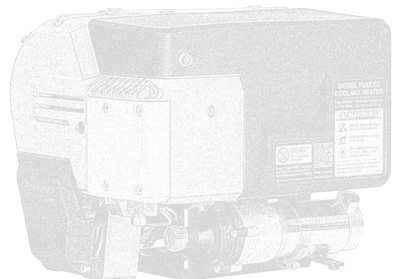

Caring for your PROHEAT

CLEAN NOZZLE

- Remove and install nozzle as per Installation & Service manual SL9211. Torque to 150 in/lbs. (17.35 Nm).
- To properly clean the nozzle use a degreaser/cleaner or carburetor cleaner in a spray can. This will wash any dirt out and leave no residue. When using compressed air, blow into the nozzle orifice **from the head end ONLY**.

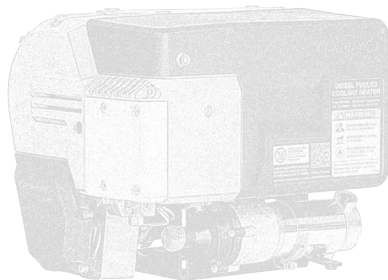

HOLD NOZZLE UPRIGHT TO ASSEMBLE

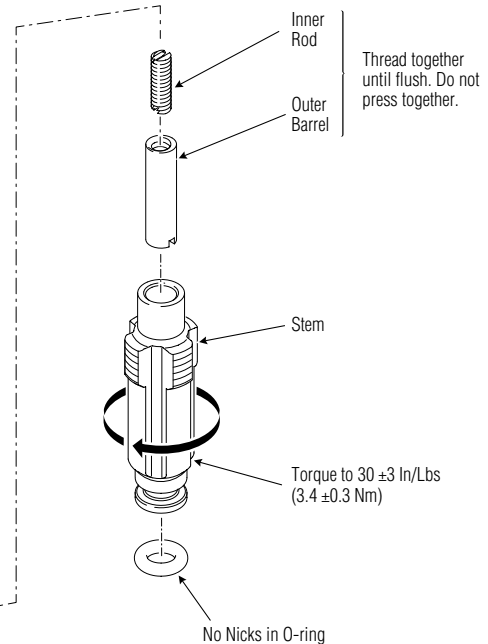
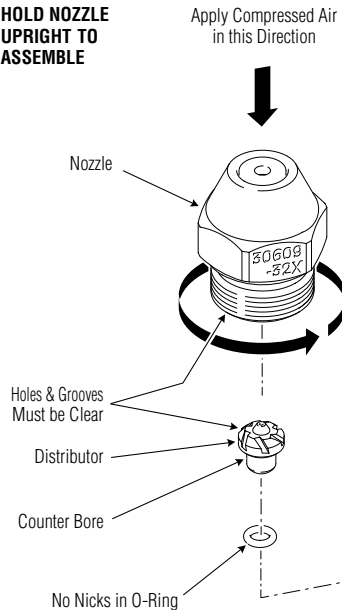

Caring for your PROHEAT

COMPRESSOR AIR FILTER

ELECTRICAL SYSTEM

TIMER / TOGGLE SWITCH

AIR PRESSURE CHECK

OPERATION TEST

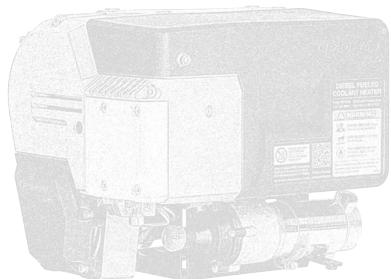

- Replace the compressor inlet air filter annually or more often if dusty conditions are encountered.

- Check the internal and the external wire harnesses for damage. Replace if required.

- Check to see that both operate as described in the Operation Manual.

- Correct air pressure is important – refer to the X30 Installation and Service manual SL9211 for further information.

- Run the system for at least 15 minutes or until the heater cycles “OFF” and then “ON” again.
- Alternate the thermostat for the sleeper heater (if connected) between the lowest and highest settings to ensure that the sleeper heater fan cycles “ON” and “OFF”.

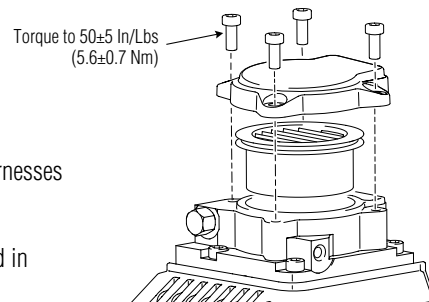

Remove Plug and Connect Fitting

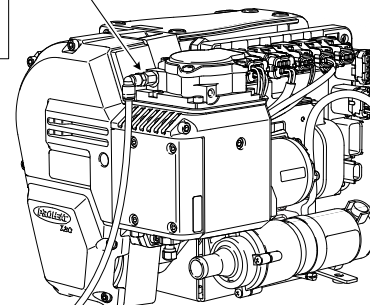

Digital Manometer PK0036

Troubleshooting

The PCM (PROHEAT Control Module) has self diagnostics for reliable operation, safety and protection of the PROHEAT. If a problem is detected it shuts the PROHEAT OFF and will start blinking the diagnostic indicator light on the PCM cover, toggle switch, timer red manual light or OEM indicator light (installation options). A diagnostic code number is also displayed on the PCM Diagnostic Panel located under the PCM cover and the optional PFC.

NOTICE

For more detailed troubleshooting information, refer to the Installation and Service manual SL9211 at www.proheat.com

TROUBLESHOOTING STEPS

1. Switch the PROHEAT ON using the toggle switch, T-II Timer or PFC.
2. Check the diagnostic code indicator located under the PCM cover on the heater. The codes are as a two digit code followed by a dash single digit code such as 01-1.
3. Function Diagnostic codes 01 to 05 are usually caused by vehicle system interface problems.
4. Components Diagnostic codes 13, 14, 19 and 21 to 29 indicate an electrical problem ONLY, with PROHEAT components, wiring or the PCM. Refer to your Installation and Service manual SL9211 for further information.
5. For an up to date Installation and Service manual SL9211 or to locate a Distributor/Dealer near you, go to www.proheat.com

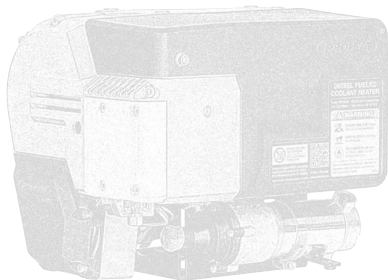

Troubleshooting

Operation Indicators/Diagnostic Codes

PROHEAT CONTROL MODULE (PCM) DISPLAY PANEL DETAIL

Operation State	Display Code No.	Description
Configuration		
CC		Configuration error or not selected.
Function Diagnostics		
Start	01-1	O ₂ low.
	01-2	O ₂ high.
	01-3	EGT temp low.
Flame Out	02-1	O ₂ low.
	02-2	O ₂ high.
	02-3	EGT temp low.
	02-4	Fuel command low.
	02-5	Unstable flame.
Coolant Flow	03-1	Coolant flow.
Overheat	04-1	Coolant.
	04-2	Exhaust.
Voltage	05-1	Voltage low.
	05-2	Voltage high.
	05-3	Voltage surge.

* Warning code. Heater will continue to operate.

Operation State	Display Code No.	Description
Component Diagnostics		
Temp. Sensors	07-1	Range low.
	07-2	Outlet range high.
	07-3	No communication.
	07-4	Temperature mismatch.
Fuel Valve	08-1	Electrical.
Compressor	09-1	Short circuit.
	09-2	Overload.
	09-3	Open circuit.
	09-4	Speed.
	09-5	PCM damage.
Ignition Module	10-1	Short circuit.
	10-2	Not used.
	10-3	Open circuit.
Coolant Pump	11-1	Short circuit.
	11-2	Overload.
Blower Motor	12-1	Short circuit.
	12-2	Overload.
	12-3	Open circuit.
	12-4	Speed.
	12-5	PCM damage.
System Current	16-1	Short circuit.
	16-2	Overload.

Operation State	Display Code No.	Description
Component Diagnostics Continued		
O ₂ Sensor	17-1	No communication.
	17-2	Out of range.
	17-3	Performance.
CAN	18-1	No heartbeat.
PCM Temp*	19-1	PCM temperature high.
Output 1-6	21 to 26	Short circuit.
PCM Battery Power	31-1	Supply low.
EGT Sensor	32-1	Range low.
	32-2	Range high.
Impact Switch	33-1	Active.
PCM	34-1	Hardware failure.

NOTICE

LOCKOUT MODE – After 6 consecutive start faults (Code 01) or on the first occurrence of Overheat (Code 04) the X30 PCM will go into Lockout mode, Power to the X30 PCM must be removed and reapplied to exit Lockout mode.



Troubleshooting

Operation Indicators/Diagnostic Codes

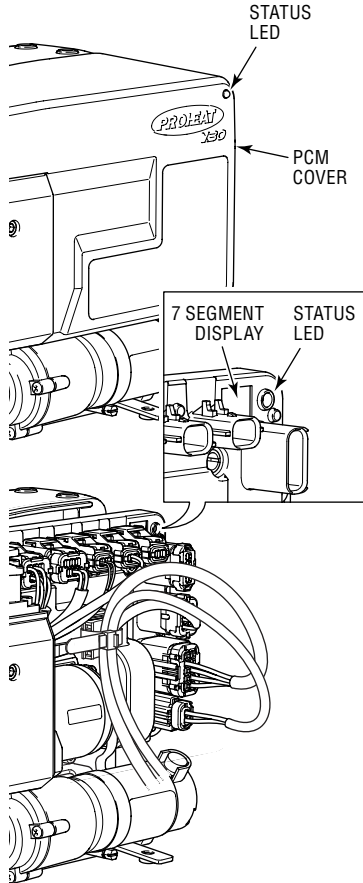

PCM Cover Status LED

The PCM continually monitors the PROHEAT operating conditions. When operating correctly the PCM status LED will be Green. If the PCM detects a problem, the PCM status LED blinks Red, indicating a diagnostic code(s) is being displayed on the PCM's 7 segment display located under the PCM cover.

The diagnostic indicator light may also be located:

- In the toggle of the ON/OFF switch provided by PROHEAT (standard installation kit).
- In the PROHEAT T-II Timer manual ON light (red).
- In the PFC manual mode button ON light (red).
- In an OEM indicator light package.

PCM Status State	Light Colour	
GREEN	Flash twice (fast) then off	When power is first applied to the PCM the Green LED will flash (fast) twice to indicate that the PCM has booted up
GREEN	On solid	Heater is switched on Via analog switch inputs and is operating normally
GREEN	Off then two flashes, then off again	Heater is connected to CANBus network and is communicating on the network but is not switched on
GREEN	On solid with two flashes then on solid again	Heater is switched on Via Analog or CANBus switch inputs and is operating normally and communicating on the network
RED	On solid	Software problem detected. Contact Proheat for further information.
RED	Blinking	Indicating a diagnostic code(s) is being displayed on the PCM's 7 segment display located under the PCM cover

Troubleshooting

Operation Indicators/Diagnostic Codes

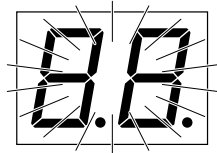

Power Up



On

OPERATION INDICATORS

Operation States:

- Power Up
- Right (•) – On
- Left (•) – Cool Down (Purge)

The operation indicators signal normal functioning of the PROHEAT. These three states do not indicate a fault.

The power up indicator communicates that the PROHEAT power has been supplied. All segments of the LED momentarily flash “” twice, followed by a 2 second display of the configuration code number (if configuration is set) or “” (if configuration is not set).

The ON indicator code communicates:

On solid – Heater is switched on via analog switch inputs and is operating normally.

Off then two flashes then off again – Heater is connected to CANBus network and is communicating on the network but is not switched on.

On then two flashes then on solid again – Heater is switched on Via Analog or CANBus switch inputs and is communicating on the network.

WARNING

The “ON” LED indicates that the heater can start at any time.

Refer to Installation and Service manual SL9211 at www.proheat.com

Troubleshooting

Operation Indicators/Diagnostic Codes

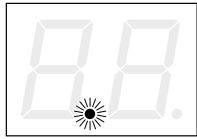

Cool Down



On indicator

Example:
LED Display showing
Code 01

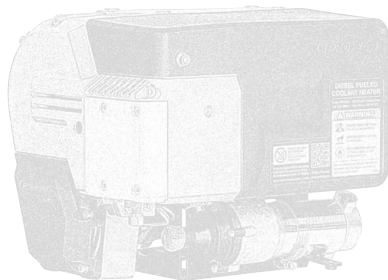

The PROHEAT will be in the Cool Down (Purge) state as defined in Modes of Operation when Cool Down LED is displayed. Refer to Installation and Service manual SL9211 at www.proheat.com

COMPONENT DIAGNOSTIC CODES:

This section covers individual electrical components. These codes indicate electrical faults **ONLY**. Mechanical failures of a component are not detected electronically and will be indicated by a Function Diagnostic Code. These diagnostic codes are not fully covered in this handbook. Refer to Installation and Service manual SL9211 at www.proheat.com

NOTICE

Diagnostic codes 03-1, 09-4, 12-4 and 19 to 26 are non critical warning codes, they will not shut the PROHEAT down. The heater will continue to run, maintaining heat to the engine.

Troubleshooting

Function Diagnostics

START (01) & FLAME OUT (02) Diagnostic Code

PROHEAT is designed to burn Diesel (ULSD #1, #2 and Arctic Blend), Kerosene (K-1), Jet (A, A-1 and JP8), Bio fuels (up to B20*). During cold weather, the correct grade of fuel or fuel blend **MUST** be used to prevent gelling and to ensure fuel flow. Problems with the fuel system are indicated by the above codes.

CHECK

Fuel level in tank and quality of fuel:

- Fuel line routing for kinks and restrictions (wire ties too tight, etc.)
- Fuel line condition (cracks, abrasions, etc.)
- Fuel filter (see Installation and Service manual SL9211 at www.proheat.com)

NOTICE

On a new installation, running out of fuel or after servicing, the fuel lines may be empty and two (2) ignition cycles may be required in order to purge the air from the fuel system when starting.

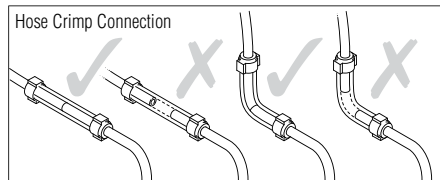

NOTICE

Six consecutive start (01) faults will put the PROHEAT into Lockout Mode. It requires power to the X30 PCM to be removed for 30 seconds and reapplied to clear the code.

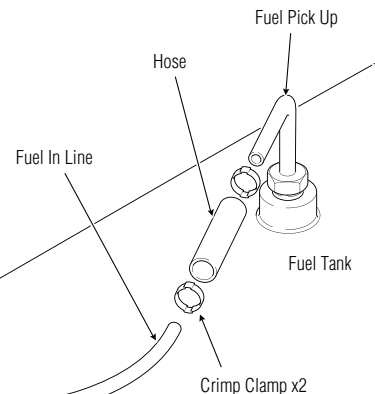
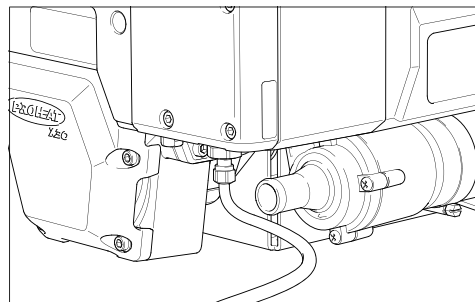
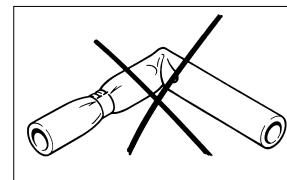

Troubleshooting

Function Diagnostics

COOLANT FLOW (03) & OVERHEAT (04) Diagnostic Codes

Proper operation of the heater requires a sufficient amount of coolant in the system and coolant flow. Problems with the vehicle and PROHEAT coolant system are indicated by the above diagnostic codes.

The OVERHEAT Code 04 will cause the X30 PCM to go into Lockout mode. Lockout mode protects the heater from damage and the coolant system must be checked thoroughly before clearing the OVERHEAT Code 04.

After checking the coolant system Power to the X30 PCM must be removed and reapplied to exit Lockout mode and clear the OVERHEAT code 04. See Installation and Service manual SL9211 at www.proheat.com for details.

CHECK

Common issues to look for:

- For at least 3 gallons of coolant in the system, ensure the radiator is topped up
- That coolant line shut off valves are open
- That sleeper heater coolant controls are in the full heat position

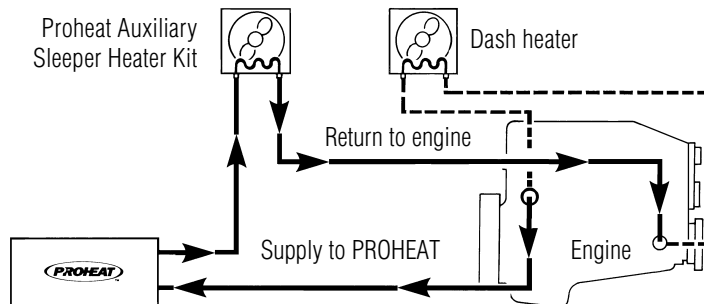
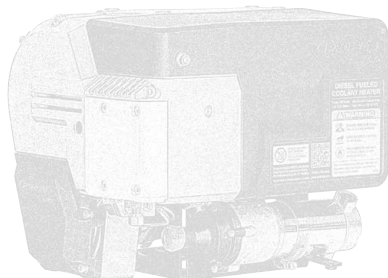

This is an example only. Vehicle may have specialized plumbing. Contact your Distributor/Dealer for details.

Troubleshooting

Function Diagnostics

VOLTAGE (05) DIAGNOSTIC CODE:

PROHEAT constantly monitors voltage at the heater. The range for a 12-volt heater is 9.5 to 32 volts and for a 24-volt heater, 19.5 to 32 volts. Should the voltage go out of this range for longer than 10 seconds, the PROHEAT will shut down and the above code will be indicated.

CHECK

Common issues to look for:

- Poor wire connections at the battery and the connector at the PROHEAT PCM
- For faulty connections at PROHEAT components and internal harness
- Battery condition (dead cells, cleanliness). Load test if necessary
- That batteries are at least 900 CCA (4 Group 31's recommended) to ensure an 8 to 9 hour use of the PROHEAT and sleeper fan
- Use of accessories such as heated mirrors, satellite receivers, refrigerators, DVD's, etc. (will shorten the time the PROHEAT can operate)
- Too high of a Fan speed selected. Use the lowest fan speed needed in order to move the hot air throughout larger sleepers.

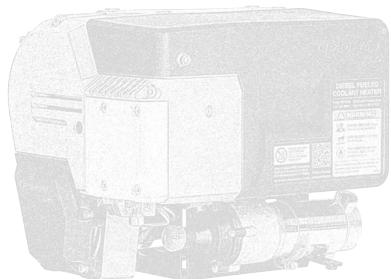

NOTICE

SeaStar Solutions warrants the PROHEAT Heater to be free of defects in material and workmanship under design usage and service conditions for two (2) years. Replacement parts are covered for the remainder of the heater's warranty or ninety (90) days, whichever ever is greater.

This warranty does not apply to damage or failure of the PROHEAT Heater or the vehicle into which it was installed due to improper installation, assembly, maintenance, abuse, neglect, accident, or the use of parts not supplied by SeaStar Solutions. Accessories supplied, but not manufactured by SeaStar Solutions, shall be covered by the manufacturer's warranty only and not subject to this warranty.

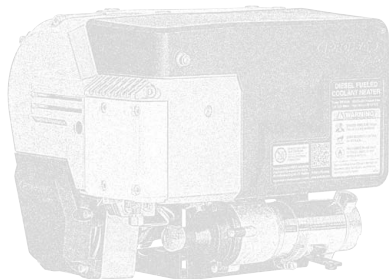

Warranty

This is a warranty summary. For the complete warranty manual, please go to www.proheat.com

Non-standard installations, that is, those requiring a departure from published installation instructions, should not be undertaken without first having consulted SeaStar Solutions.

Coverage for warrantable parts, at the discretion of SeaStar Solutions will be made to the claimant in the form of repair, replacement or credit. Warranty labour payments will be made only to Registered PROHEAT Service Centres in accordance with the Standard Repair Times (SRT's) as published by SeaStar Solutions.

Marine installations

The purchaser and installer are advised that specific rules and regulations are in effect with respect to the installation of heaters in marine applications. These rules and regulations are enforced by regional and federal agencies and/or other agencies having jurisdiction. It is the installer's responsibility to review and comply with all such rules and regulations.

In addition each marine installation must be inspected and approved by an Authorized PROHEAT Dealer. Only those installations which are approved, and so registered, will be eligible for warranty coverage of one (1) year on parts and labour.

THE WARRANTIES SET FORTH HEREIN ARE THE SOLE WARRANTIES MADE BY SEASTAR SOLUTIONS IN REGARD TO THE PROHEAT HEATER SYSTEM. SEASTAR SOLUTIONS MAKES NO OTHER WARRANTIES, EXPRESSED OR IMPLIED, OF MERCHANTABILITY OR FITNESS FOR A PARTICULAR PURPOSE.



Before the expiration of the warranty, Owner must give notice to a Registered PROHEAT Dealer of failures, if any, considered to be warrantable and deliver the defective heater system to such dealer. Owner is responsible for the cost of all repairs made to the engine or equipment in which it is installed, other than the PROHEAT Heater system. Owner is responsible for lodging, meals and incidental costs incurred by the Owner as a result of a warrantable failure. Owner is responsible for "down-time" expenses, and all business costs and losses resulting from a warrantable failure.

SEASTAR SOLUTIONS IS NOT RESPONSIBLE FOR INCIDENTAL OR CONSEQUENTIAL DAMAGES.

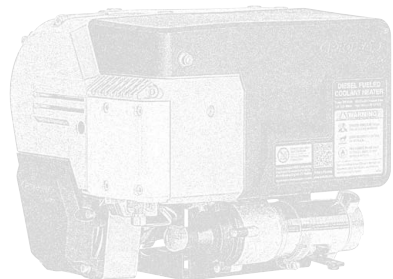

Owner's responsibility

Items Covered Under This Warranty

1. Basic Heater including combustion chamber components, fuel system components, air compressor, ignition components, coolant pump, air blower.
2. Electrical controls provided by PROHEAT including cab mounted controls and PCM.
3. PROHEAT supplied accessories and mounting hardware.

Items Not Covered Under This Warranty

1. PROHEATs no longer within the warranty period.
2. Normal wear and maintenance parts, including fuel filter, air filter, nozzle, and clamps.
3. Parts which malfunction due to improper installation, causing inadequacies in: air, fuel or coolant flow; voltage due to wiring; shock or vibration protection.
4. Any progressive damage to the engine or vehicle arising out of failure of the PROHEAT.
5. PROHEATs which have been modified or use of non-standard parts not approved by SeaStar Solutions.
6. PROHEATs that have been abused or damaged.
7. Travel time by a PROHEAT Dealer.
8. Diagnosis or repairs when caused by problems not directly related to the heater or due to empty fuel tanks or poor fuel quality.

IF YOU HAVE ANY QUESTIONS OR CONCERNS ABOUT THE PROHEAT WARRANTY, CONTACT YOUR NEAREST PROHEAT DISTRIBUTOR OR SEASTAR SOLUTIONS AT (604) 270-6899.



SeaStar Solutions

3831 No.6 Road
Richmond, B.C.
Canada V6V 1P6

Tel: 604-270-6899
Fax: 604-270-7172

www.proheat.com



ISO 9001



Designed and Manufactured
in North America

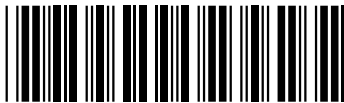

PID# SL9210 REV. A

©2017 Marine Canada Acquisition Inc. (DBA SEASTAR SOLUTIONS)

Proheat is a registered trademark of Marine Canada Acquisition Inc. and its subsidiary companies.

Printed in Canada 06/17

