

PDCN	REV.	APPV DATE	REVISIONS	DWN	DSGN	CHK	APPV
			INITIAL ISSUE				
2002141	1	05/30/02	54.55±0.8 WAS 54.55±0.3	RSR	MH	DRL	RG
2003033	2	3/28/03	ADDED WEIGHT 7.6 kg (16.8 lb)	JS	DS HF	DRL	RG
2003099	3	06/09/03	37.88 MAX WAS 44.8 MAX 146.2±0.6 WAS 148.8±0.6	RSR	MH	DRL	NB
2006310	4	12/11/06	PRV: 4307-6470 WAS 4967-6470	RSR	JW	DRL	TK

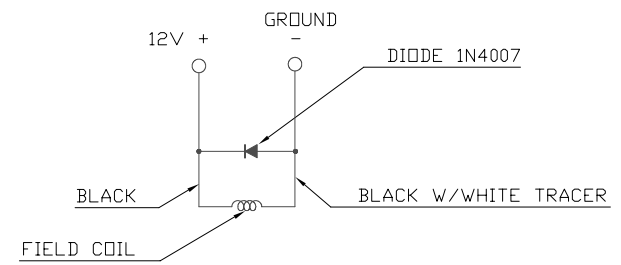

CIRCUIT DIAGRAM

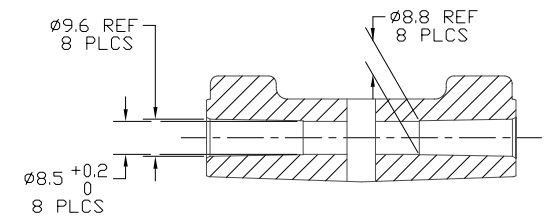

SECTION A-A

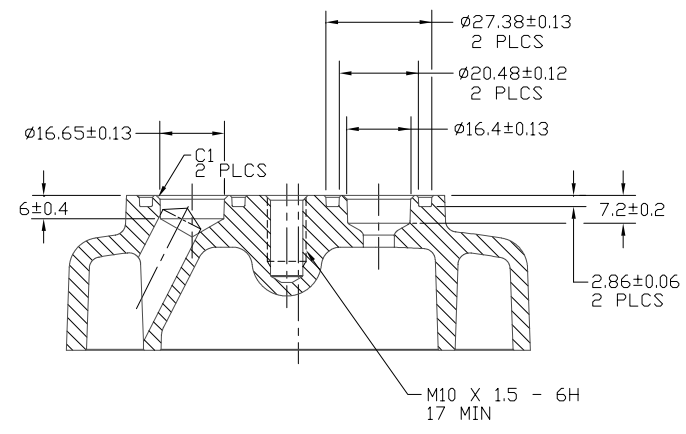

SECTION B-B
(SECTION WITH O-RINGS, SHIPPING PAD ASSEMBLY, AND BOLT REMOVED)

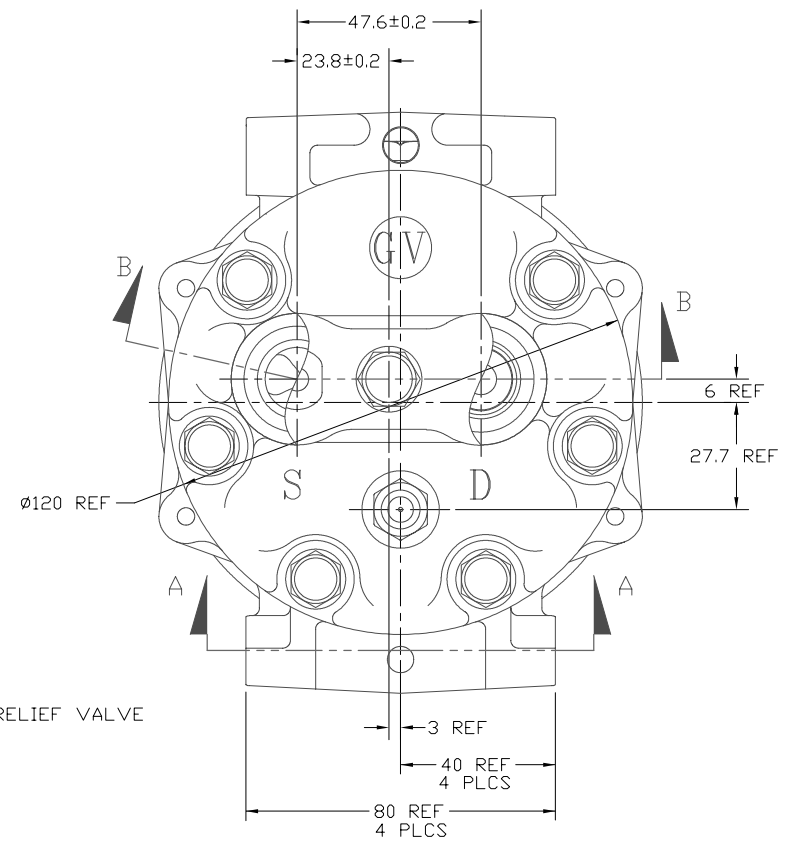
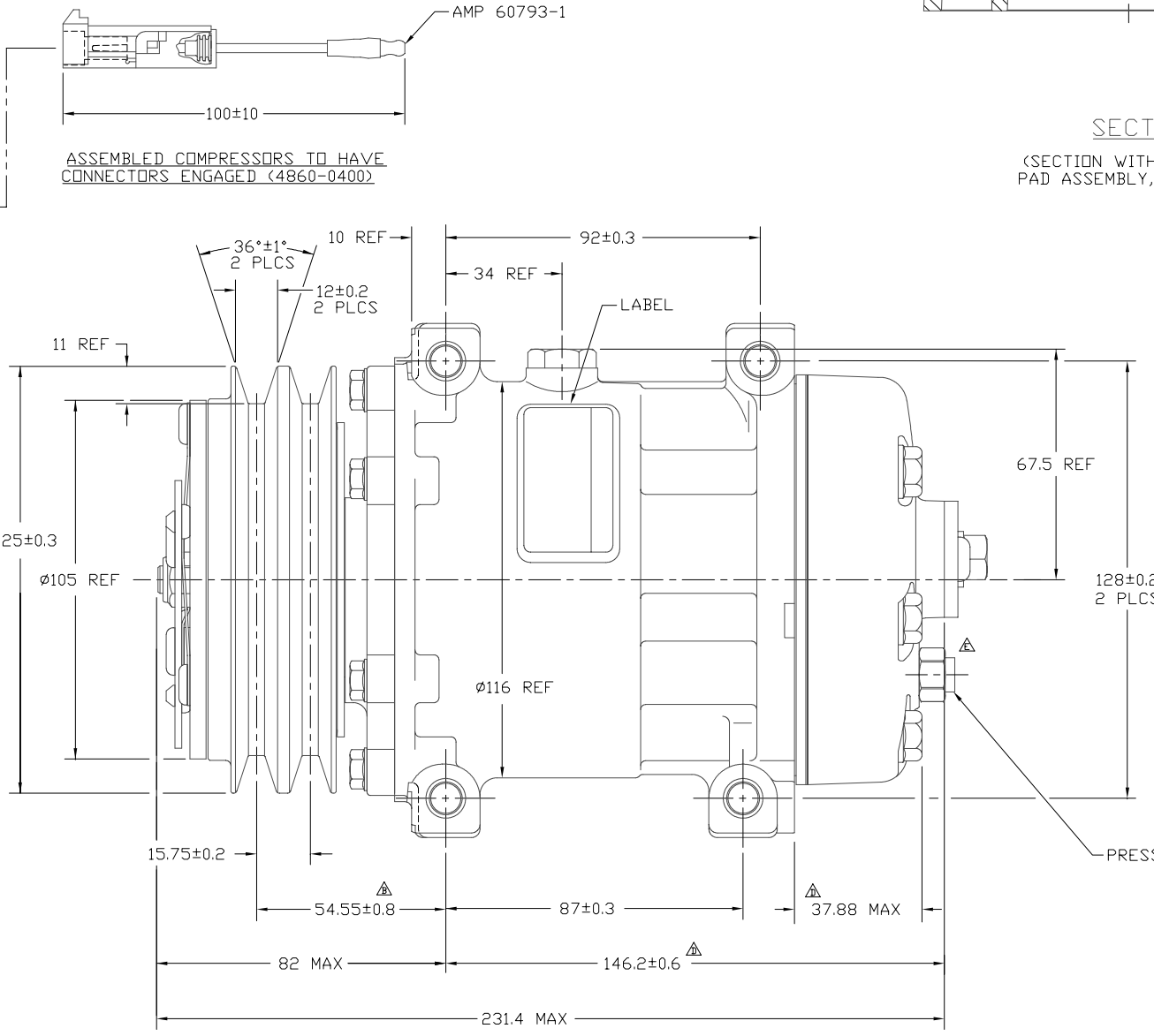
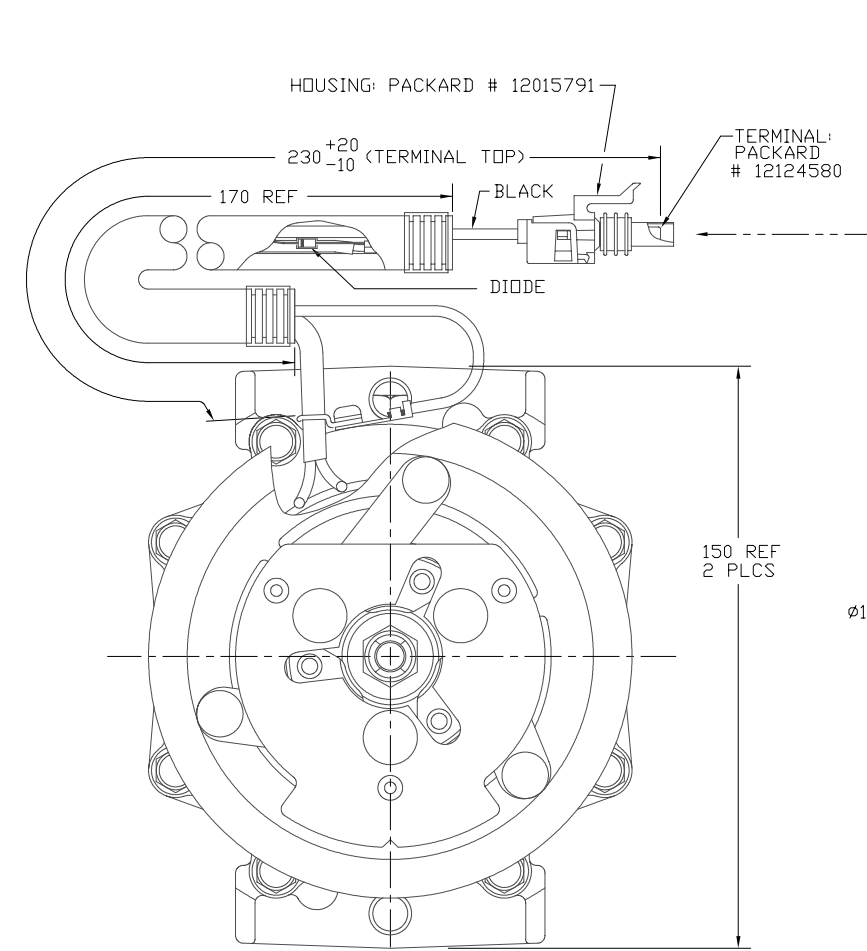

CLOCKWISE ROTATION

NOTE:
1. N₂ HOLDING CHARGE DELETED.

COMPRESSOR SPECIFICATIONS (REF)

DISPLACEMENT PER REVOLUTION	154.9 cc / rev. (9.5cu.in. / rev.)
MAXIMUM ALLOWABLE R.P.M.	8000 R.P.M.
MAXIMUM ALLOWABLE CONTINUOUS R.P.M.	6000 R.P.M.
REFRIGERANT	R134a
OIL (SP-15)	200 cc (6.76 fl.oz.)
WEIGHT	7.6 kg (16.8 lb)

CLUTCH SPECIFICATIONS (REF)

RATED VOLTAGE	DC 12V
BREAKAWAY TORQUE	3.5 kgf-m min. @ 12V
MINIMUM ENGAGEMENT VOLTAGE	7.5V @ AIR GAP 0.6mm
POWER CONSUMPTION	49 watts max.
BELT TYPE	A TYPE
MAXIMUM ALLOWABLE BELT TENSION	60 kgf per belt
PULLEY DIAMETER	125 mm (4.92 in.)
CLUTCH TYPE	HEAVY DUTY

DO NOT SCALE

REV. LEVEL	RELEASED FOR: ENGG. DEVELOPMENT	<p>SANDEN INTERNATIONAL (U.S.A.), INC.</p>
DSGN	P. Nauculich	
CHK	J. Sokolowski	DRAWN SCALE REF 1:1 PLOTTED SCALE REF NONE METRIC
APPV.	R. Garver / J. Colhoun	<p>This drawing and the information contained hereon are CONFIDENTIAL and PROPRIETARY to Sanden International (U.S.A.), Inc., and are received in CONFIDENCE and shall not be used, copied, or disclosed to others without the written permission of Sanden International (U.S.A.), Inc.</p>
DATE	04/25/02	
REV. LEVEL	RELEASED FOR: DESIGN VALIDATION	INTERPRETATION OF THIS DRAWING PER ASME Y14.5M-1994
DSGN	M. Harrington	THIRD ANGLE PROJECTION
APPV.	R. Garver	SIZE D
DATE	05/30/02	
REV. LEVEL	RELEASED FOR: PRODUCTION VAL'D.	MATERIAL: -
DSGN	M. Harrington	
APPV.	R. Garver	NAME: COMPRESSOR
DATE	05/30/02	
REV. LEVEL	RELEASED FOR: PRODUCTION	DWG. NO. 4419-6000
DSGN	M. Harrington	REV. E
APPV.	N. Burnis	
DATE	11/13/02	